

特点和用途

ZQ系列直流牵引电动机系用于架线式工矿电机车，作牵引电动机，适用于一般金属矿或无爆炸危险的煤矿主巷道运输矿物。

本系列电动机为全封闭自然冷却式。能在震动、颠簸、布满尘土和潮湿的环境下工作，但不能用于防爆的工作场所。

技术规格

产品型号	小时工作制				电机重量 kg
	功率 KW	电压 V	电流 A	转速 r/min	
ZQ-4-4	3.5	97	45	960	137
ZQ-7-2	6.5	250	31	1186	165
ZQ-12	12.2	250	58	480	420
ZQ-18-3	18	250	83	1366	325
ZQ-18-4	18	550	38	1366	330
ZQ-21	20.6	250	95	600	550
ZQ-24	24	550	50.5	600	550
ZQ-30-3	30	250	135	1435	390
ZQ-30-4	30	550	62	1435	405
ZQ-30-1C	30	250	135	1435	410
ZQ-30-2C	30	550	62	1435	410
ZQ-52-1	52	550	106	1300	610
ZQ-52-2	52	550	106	1300	610
ZQ-52-3	52	250	234	1300	610
ZQ-52-4	52	550	106	1300	610
ZQ-52-5	52	250	234	1300	610
ZQ-52-6	52	550	106	1300	610
ZQ-52-7	52	550	106	1300	620
ZQ-52-8	52	550	106	1300	605
ZQ-78-2	78	550	154	1200	765
ZQ-78-6	78	550	154	1200	765
ZQ-78-6A	78	550	154	1200	815
ZQ-85-1	85	550	171	1200	840
ZQ-85-2	85	550	171	1200	850
ZQ-110	110	750	161	1212	920
ZQ350-4	350	1500	250	760	3250

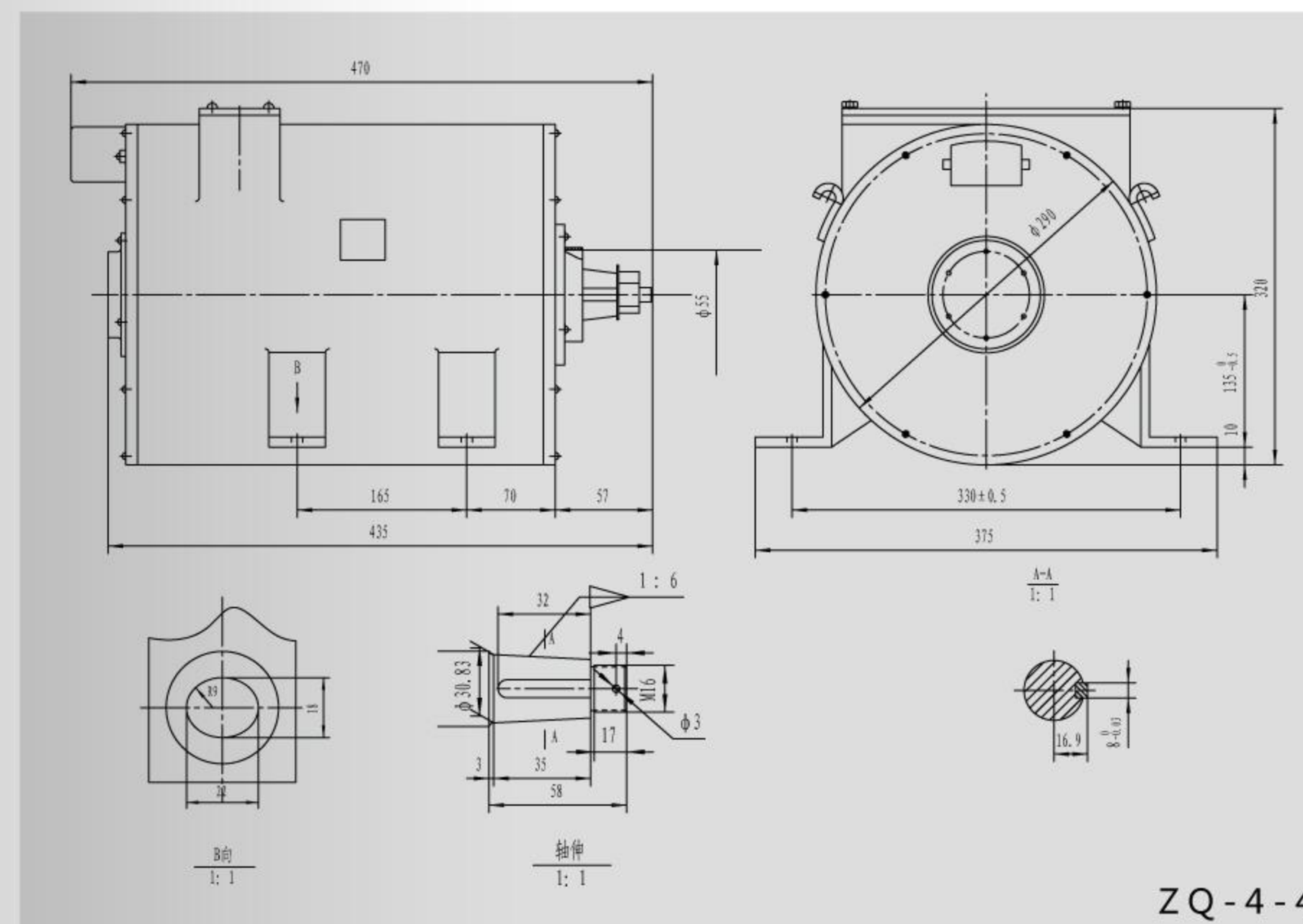

ZQ-4-4

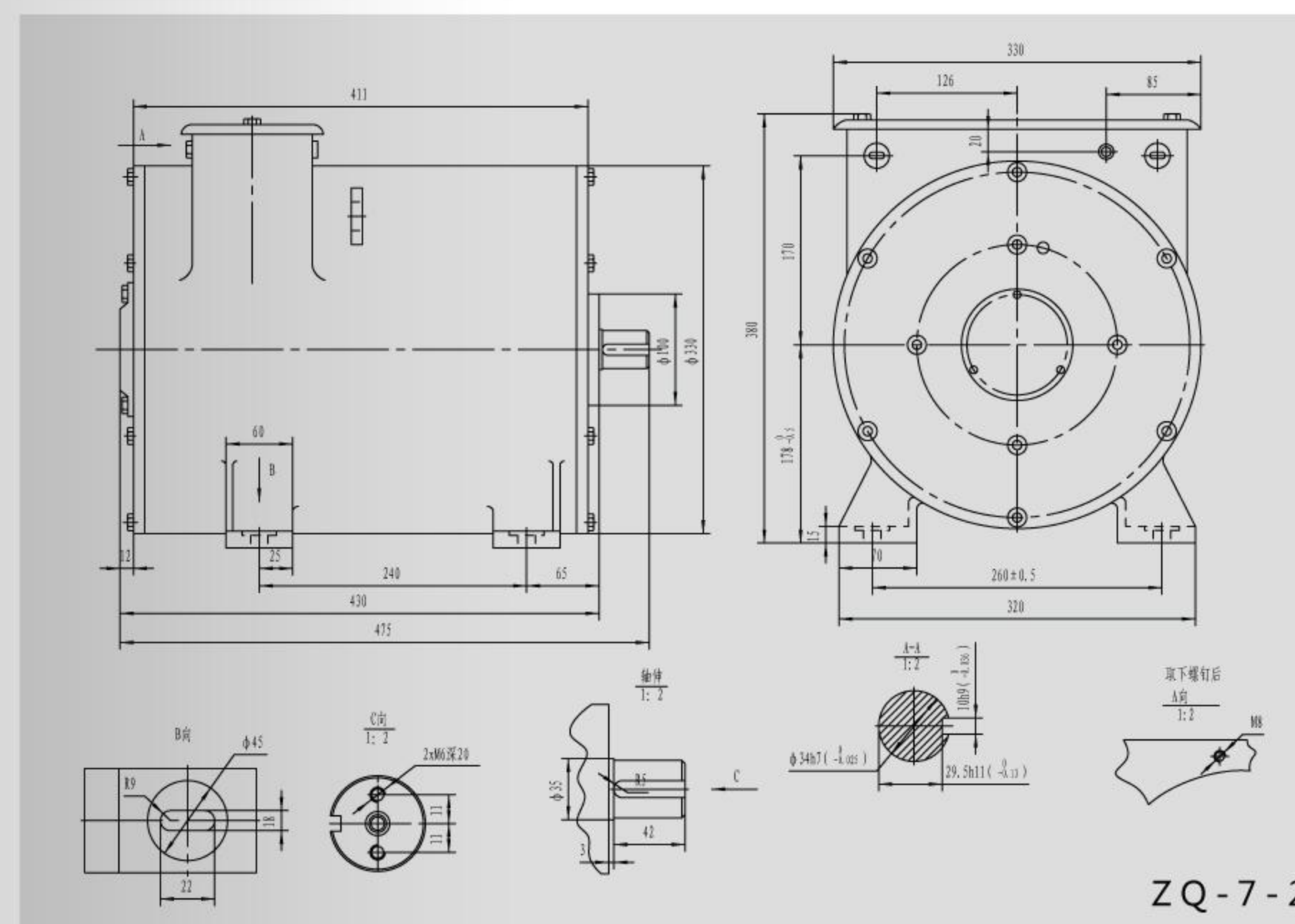

ZQ-7-2

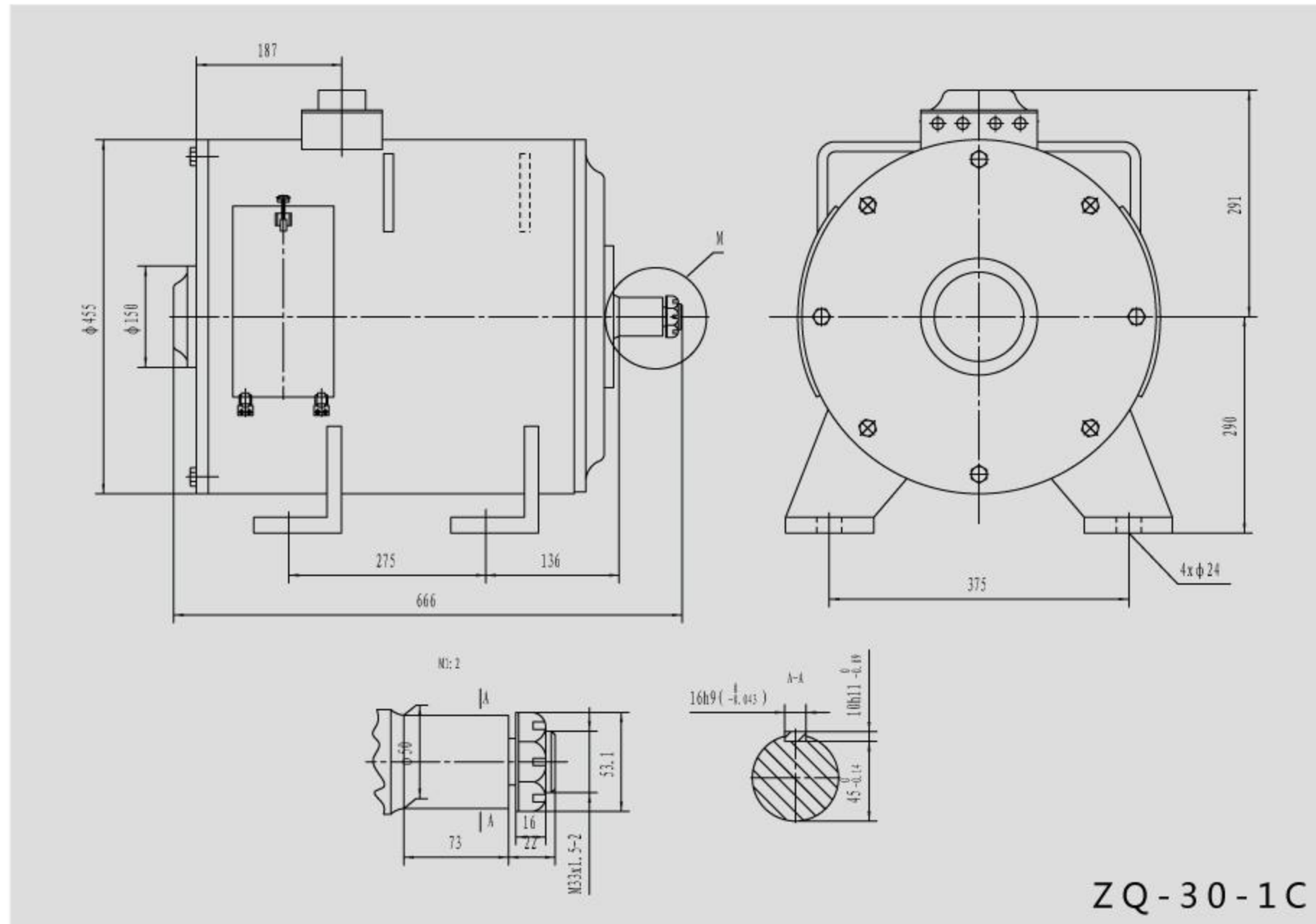

ZQ-30-1C

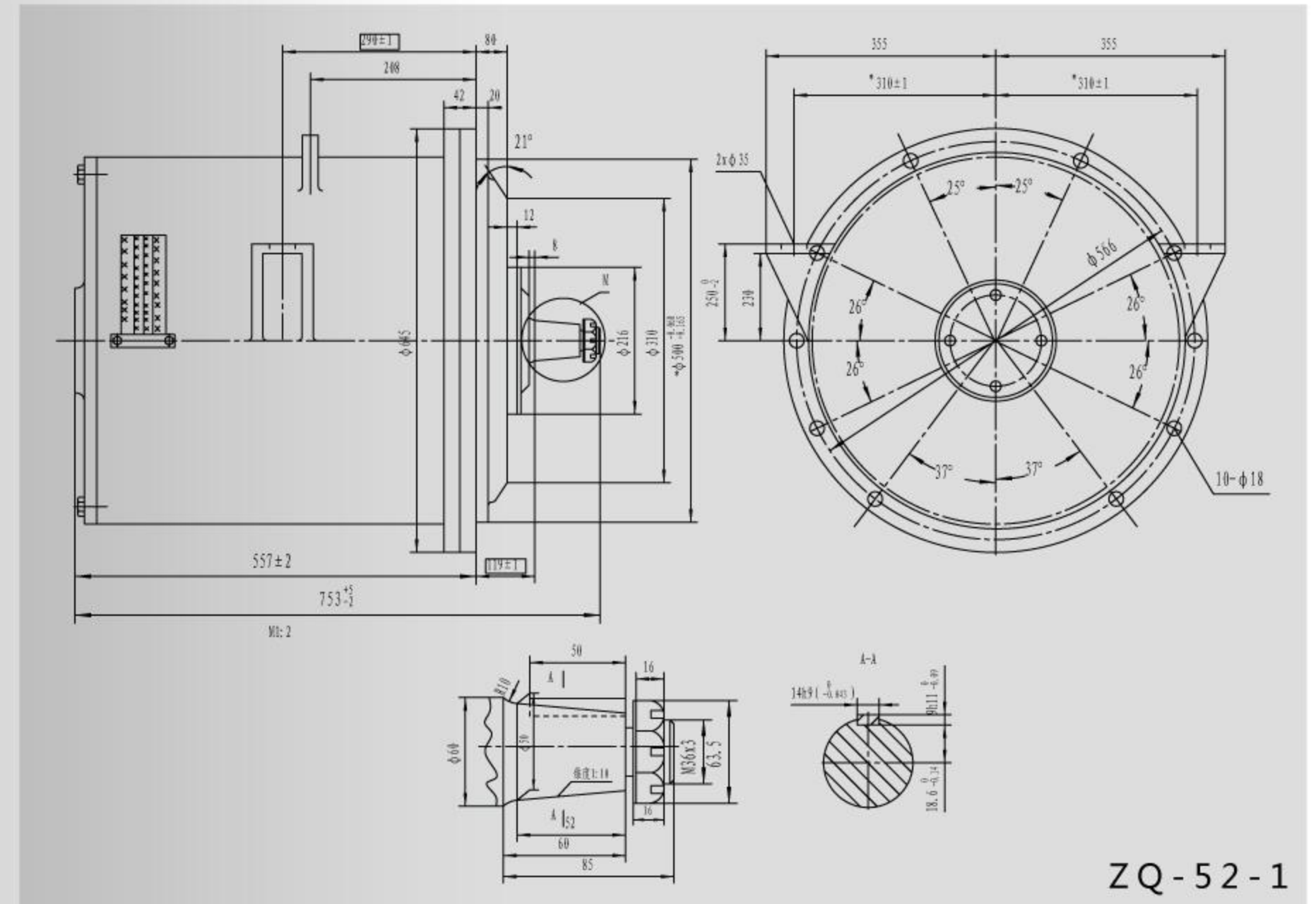

ZQ-52-1

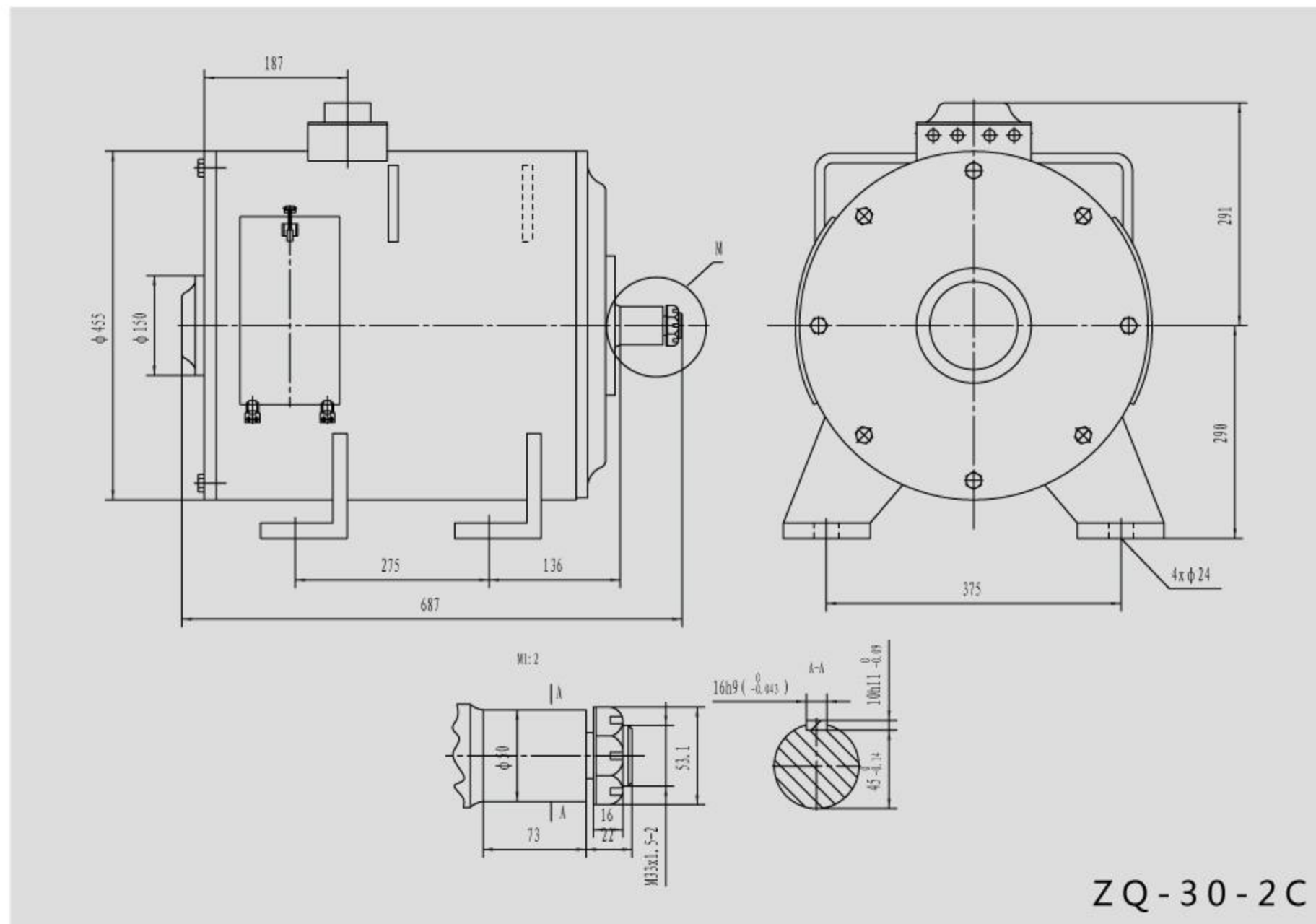

ZQ-30-2C

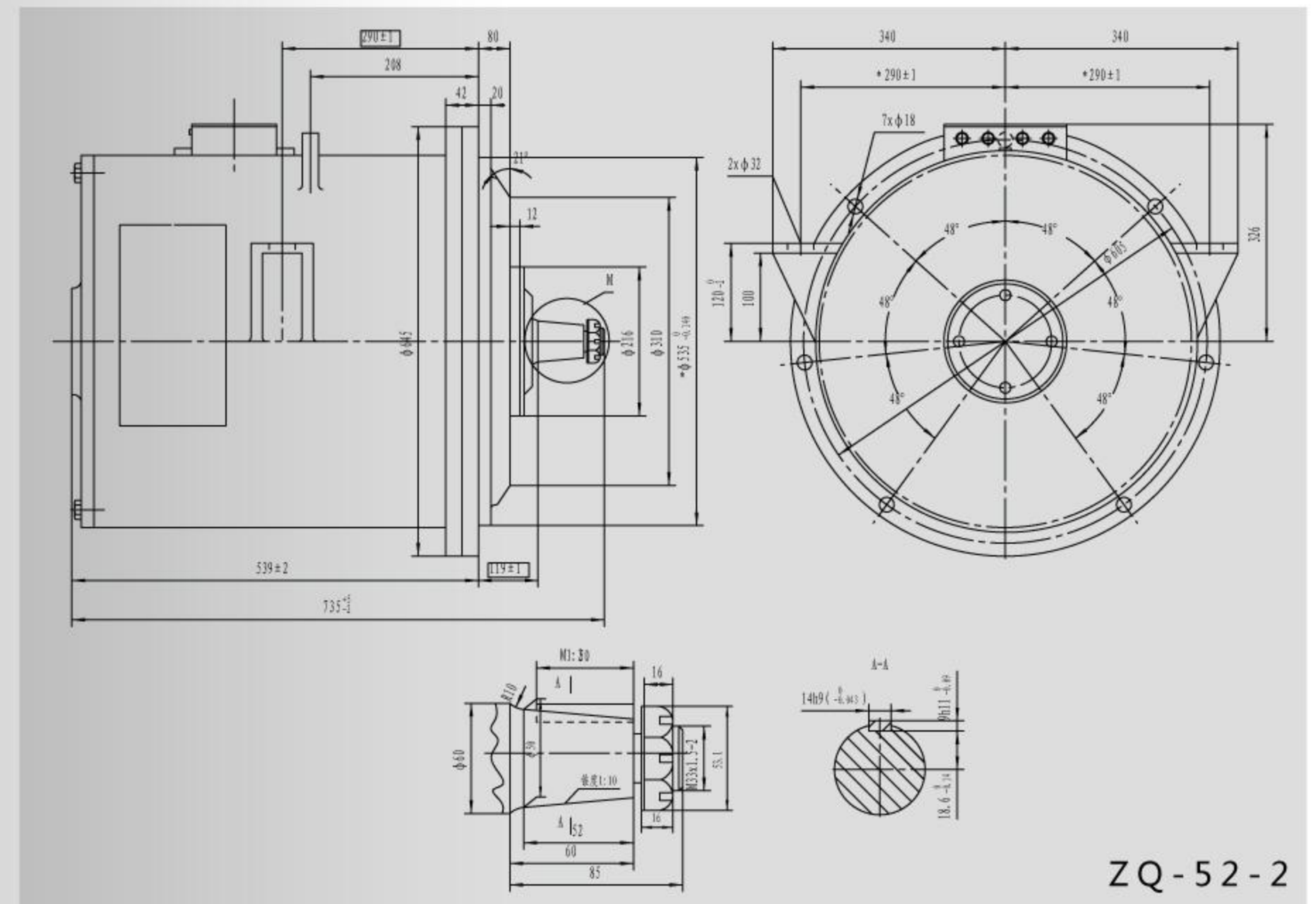

ZQ-52-2

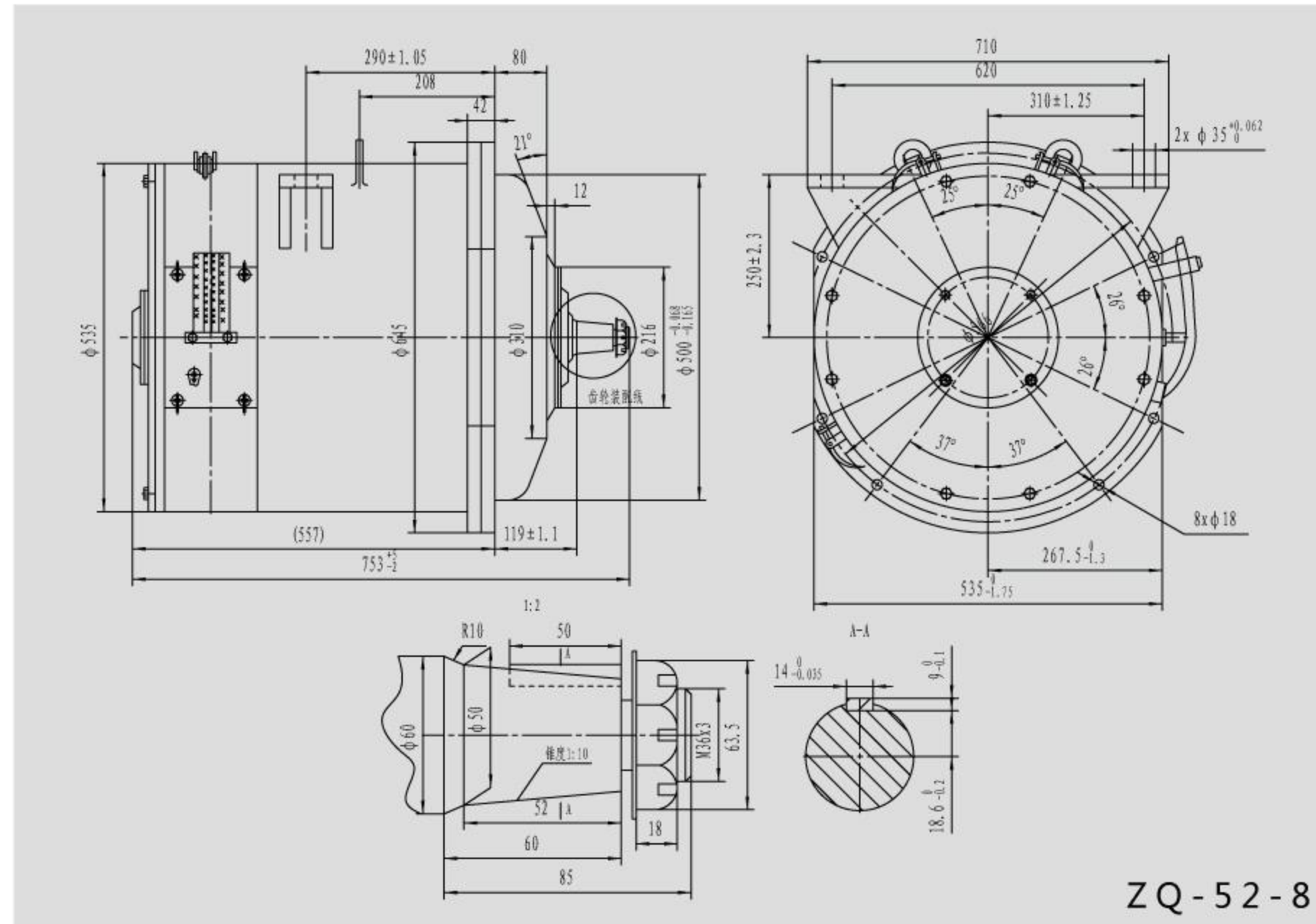

ZQ-52-8

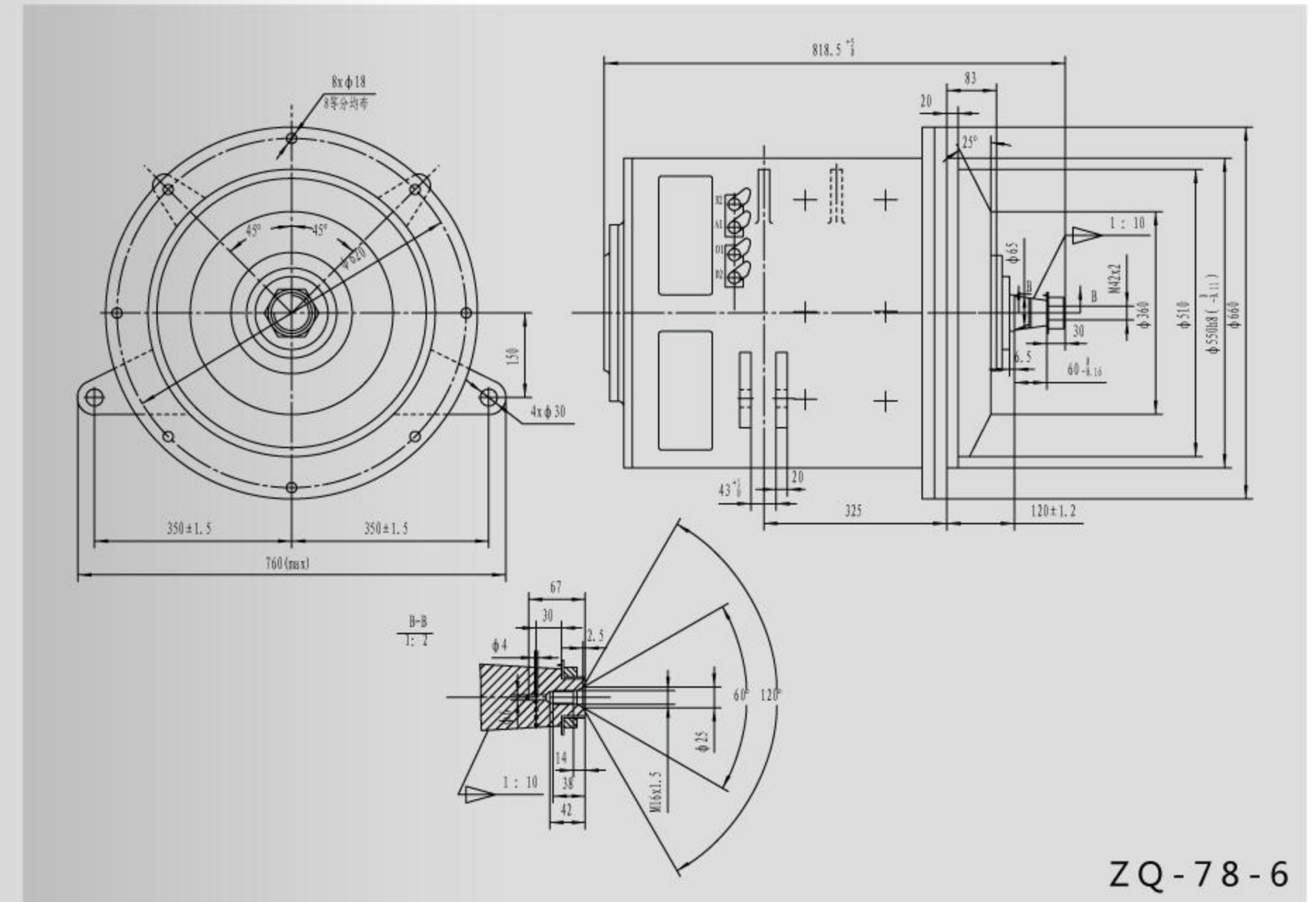

ZQ-78-6

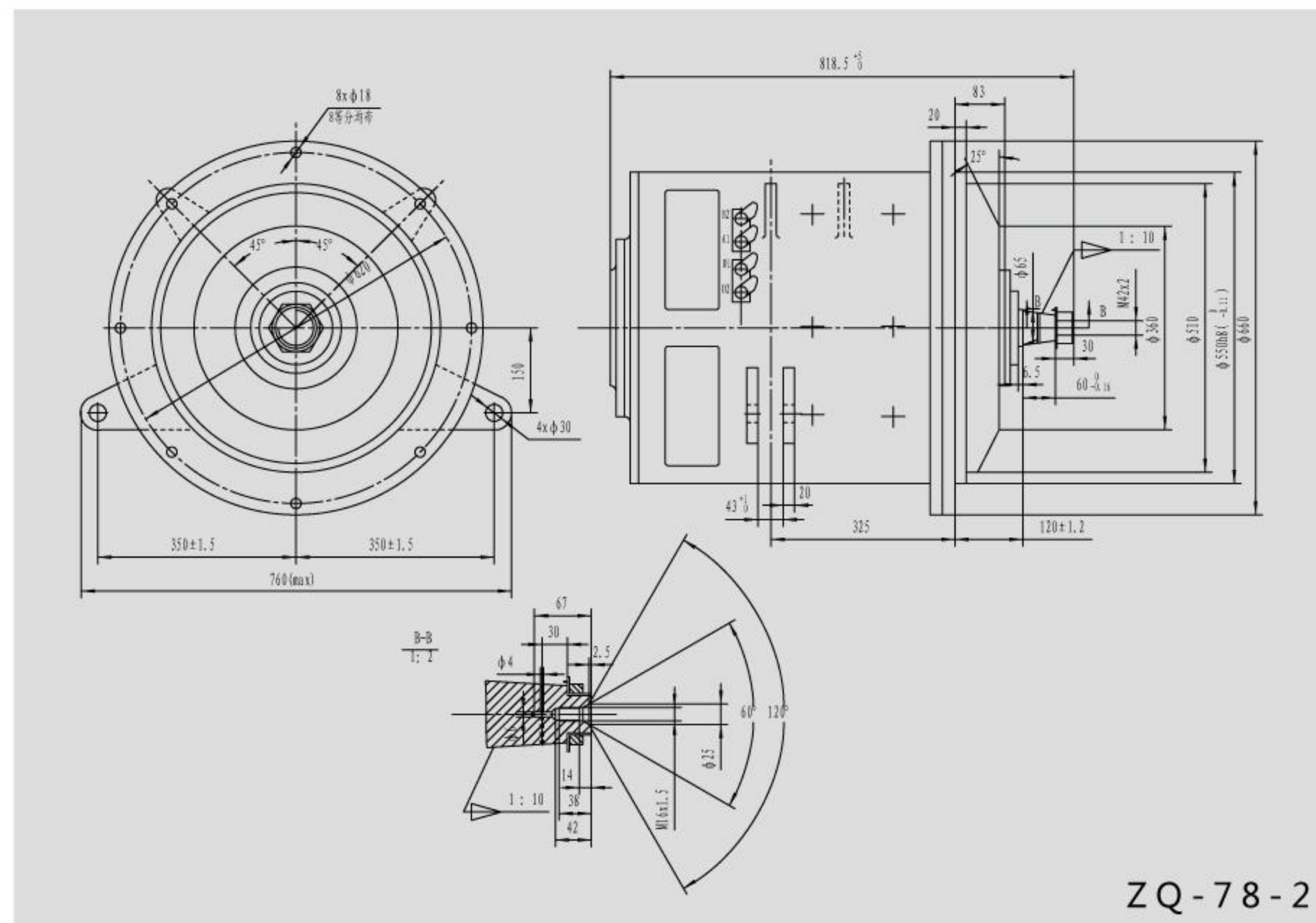

ZQ-78-2

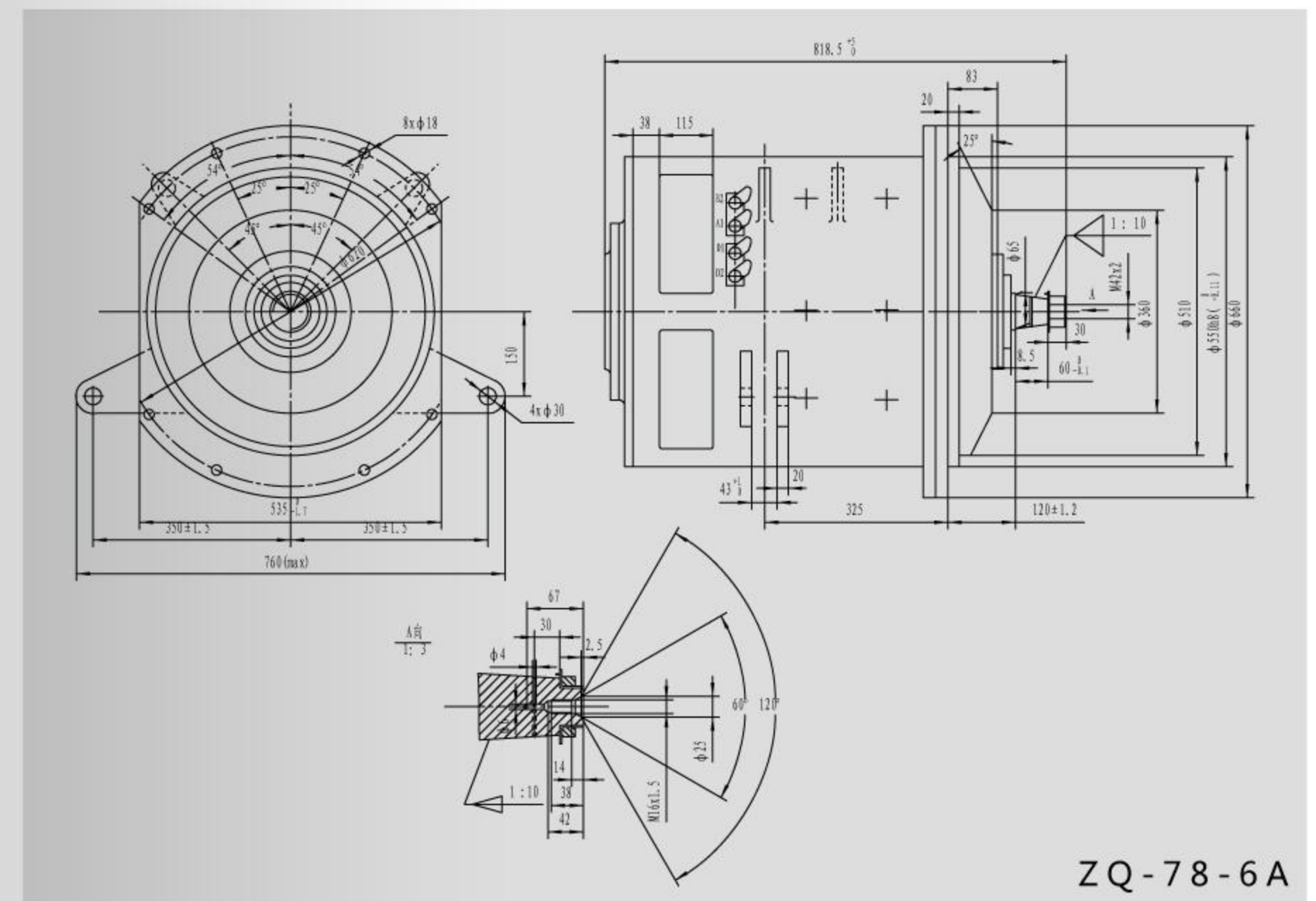

ZQ-78-6A

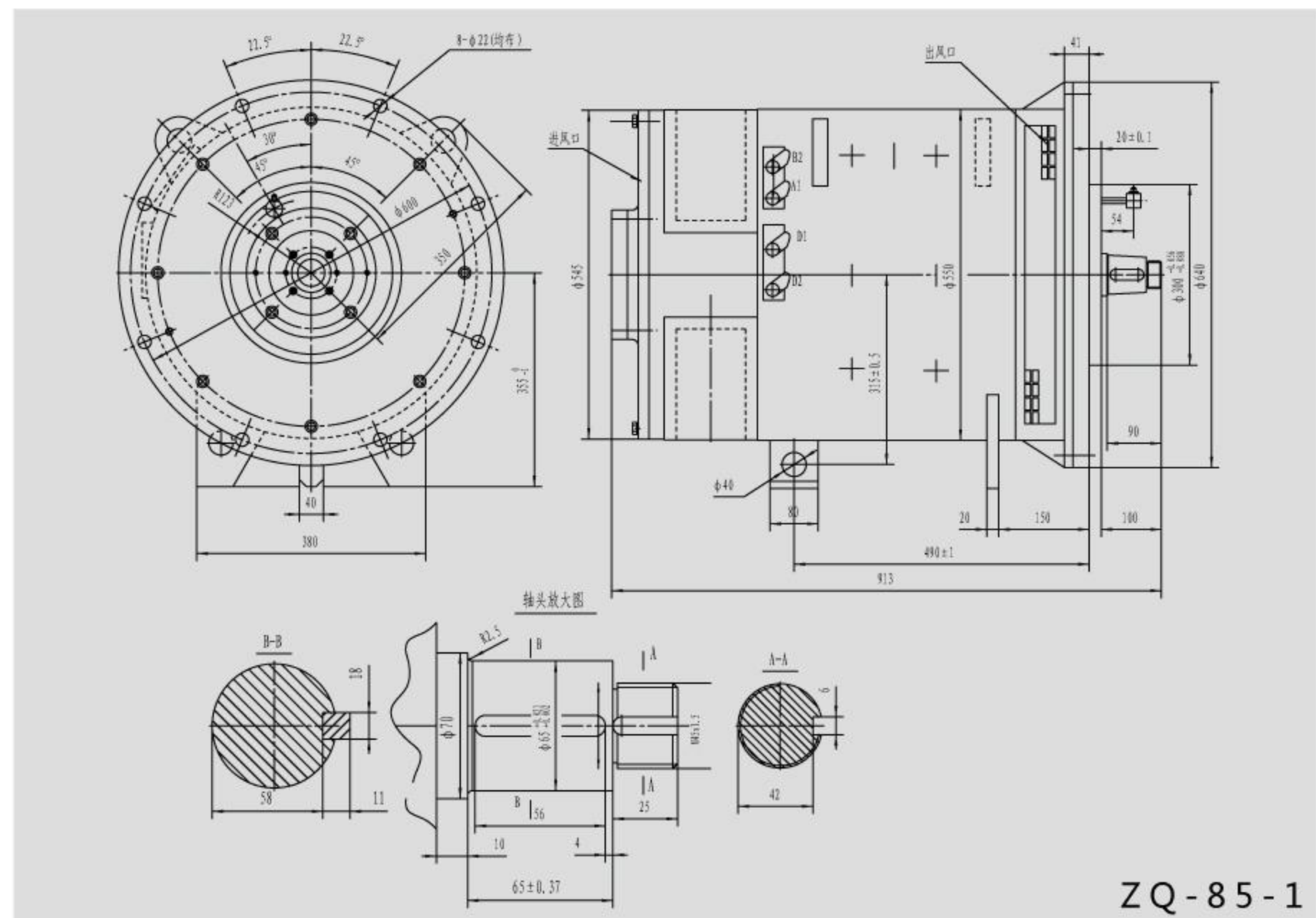

ZQ-85-1

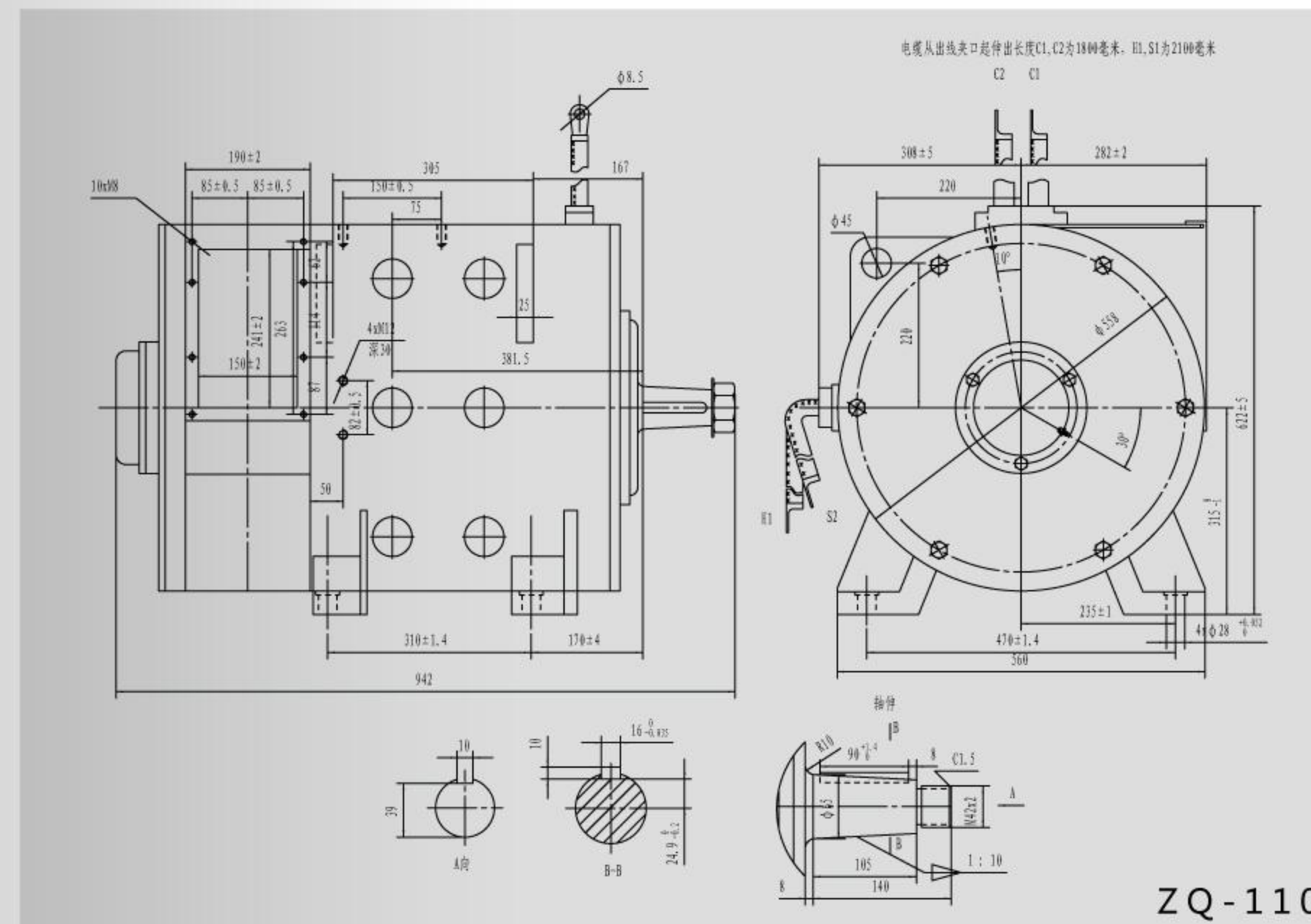

ZQ-110

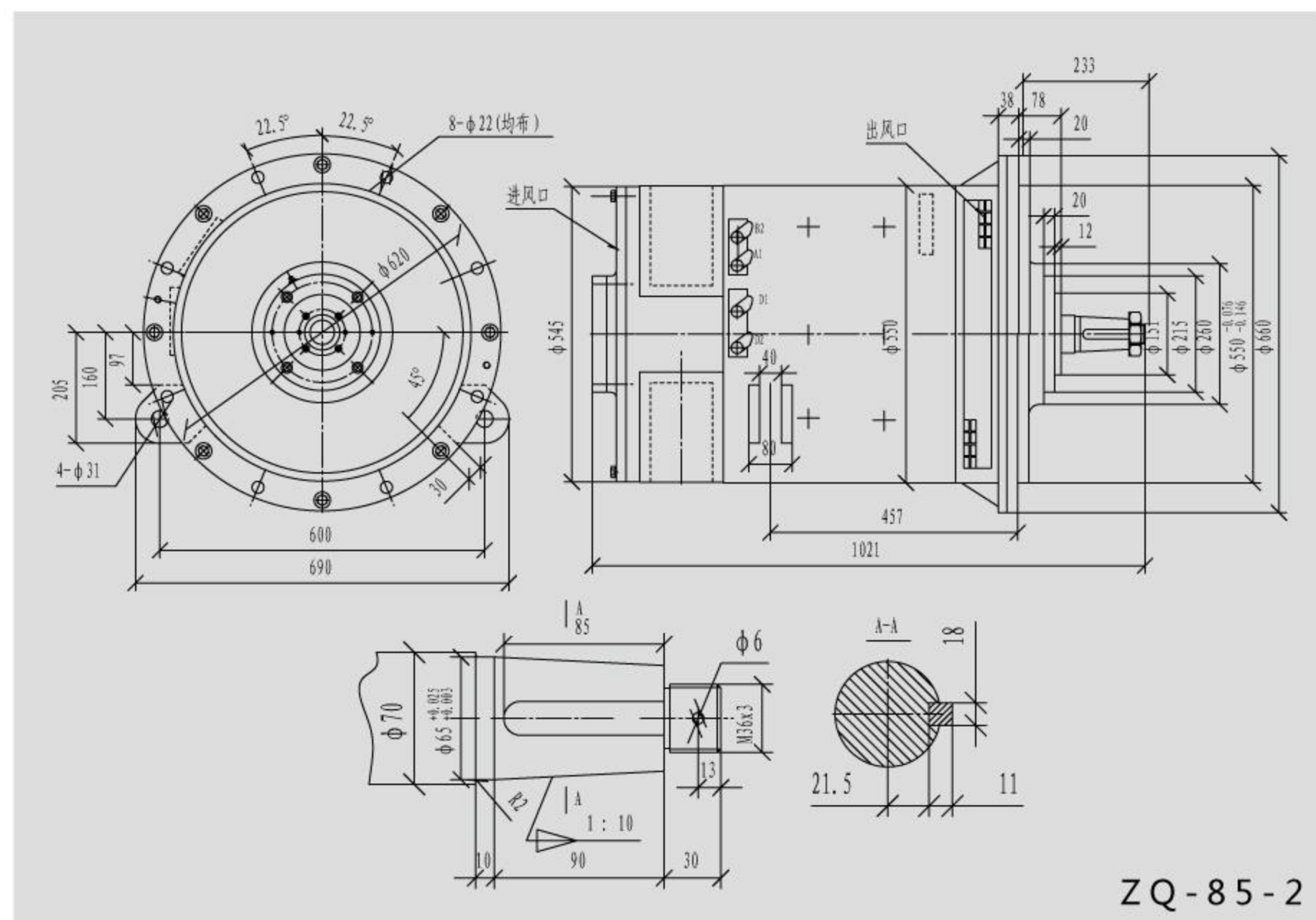

ZQ-85-2

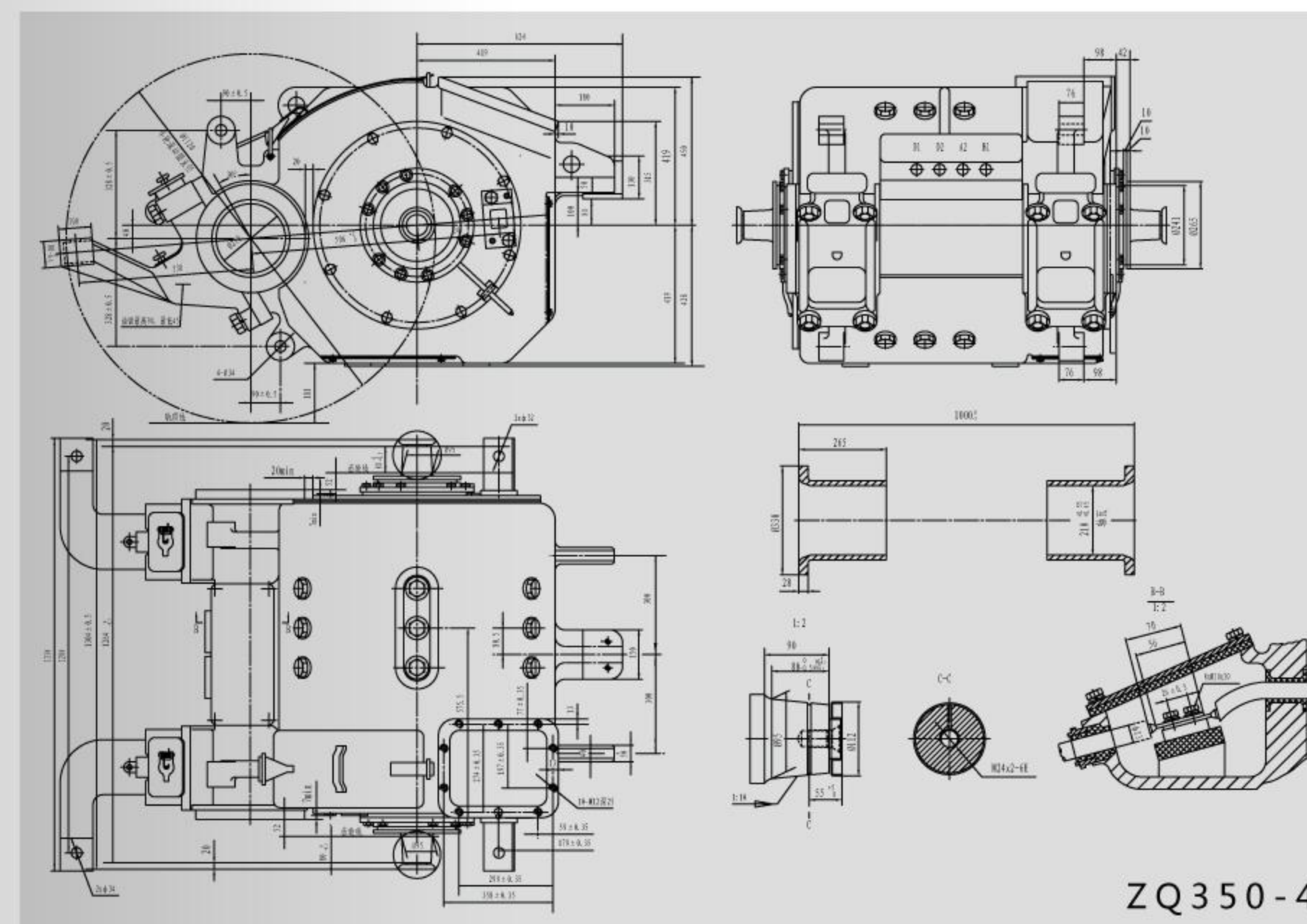

ZQ350-4